

Electro-Hyd. Circuit - JumboZ-500

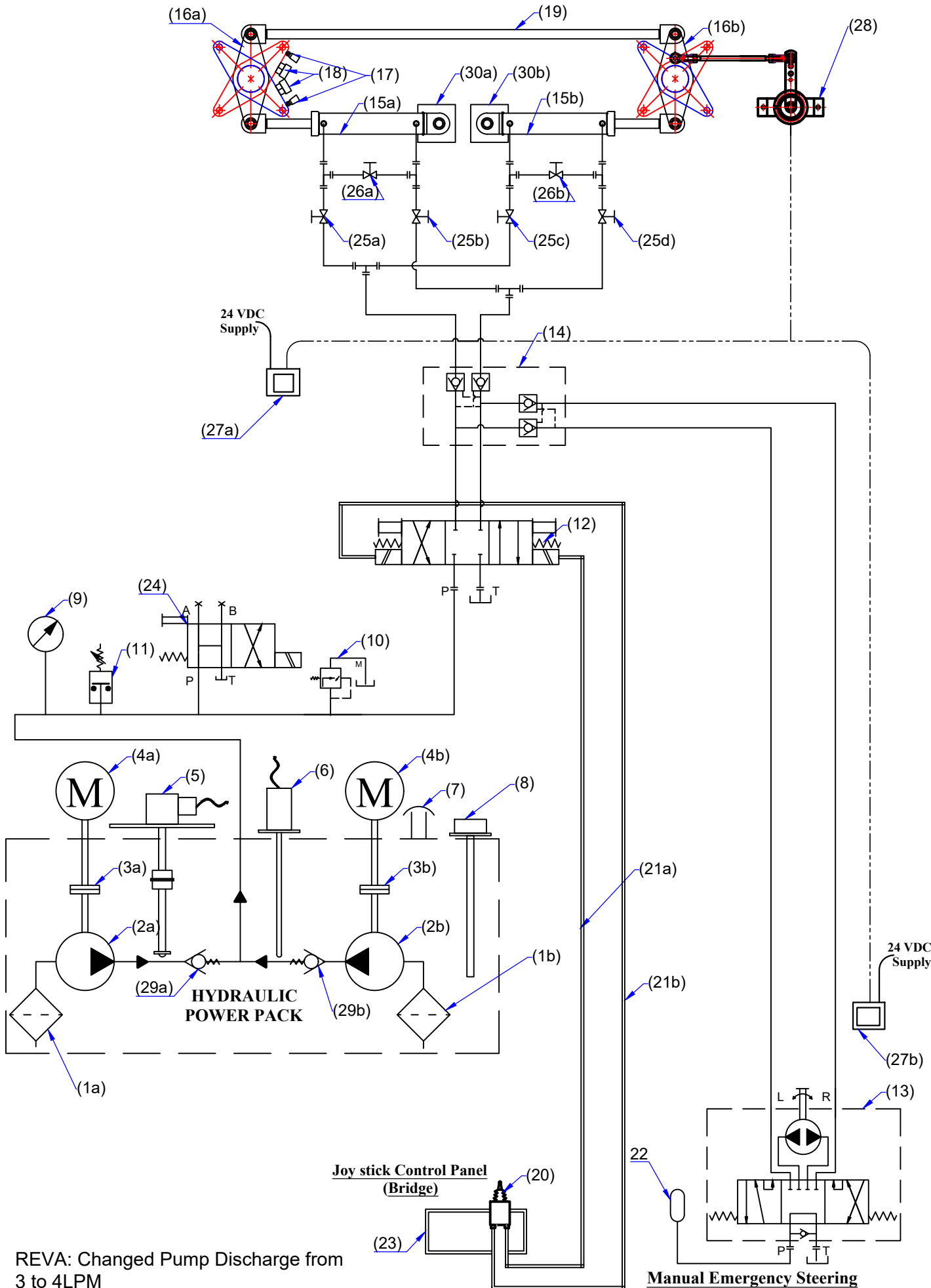

REVA: Changed Pump Discharge from 3 to 4LPM



MAC ♦ N ♦ HOM SYSTEMS
KOCHI - 20

DESIGNATION

Electro-Hydro. Circuit Twin Rudder
with Emer.Steering - JumboZ-500E

DWG. No.

MHS-1835A
(Page 1 of 2)

DATE

02.05.2023

A

B

C

D

E

F

G

H

ELECTRO-HYDRAULIC CIRCUIT SYSTEM PARAMETERS

1) Pump Capacity:

Discharge : 4 lpm

Max. Pressure : 200 kg/cm²

2) Hydraulic Cylinder

Operating Pressure : 70 kg/cm² Relief

Valve Set Pressure : 87.5 kg/cm²

3) Helm Steering Wheel

Diameter : 686 mm (27")

4) Hydraulic Cylinder

Model : JumboZ-500

Stroke : 440 mm

Ram : 40 mm x 2

5) Hydraulic Hose:

Grade : R1

I.D : $\frac{1}{2}$ "

6) Electric Motor

2 HP, 50 Hz, 1440 rpm, 3Phase

7) Emergency Helm Pump

Discharge : 80 cc/rev

Sl No.	Description
1a,1b.	Suction Strainer
2a,2b.	Hydraulic Pump
3a,3b.	Flexible Coupling
4a,4b.	Electric Motor
5	Oil Level Sensor
6	Oil Temp. Sensor
7	Filler Breather
8	Dip Stick
9	Pressure Gauge
10	Pr.Relief Valve
11	Pre.Switch.Low Pre.Alam
12	Sol.Ope.Directiona Valve
13	Emergency Manual Pump
14	Pilot Operated Double Check Valve
15a,15b	Hyd. Actuator - JumboZ 500
16a,16b	Tiller Arm
17	Limit Switch
18	Mechanical Stopper (Yard Supply)
19	Connection Rod (Yard Supply)
20	Joy Stick
21a,21b	Ele.Line to Sol.Ope.Valve
22	Reservoir
23	Steering Gear Control Panel
24	Unloading Valve
25a,25b 25c,25d	Isolation Valve
26a,26b	By-Pass Valve
27a,27b	Rudder Angle Indicator
28	Rudder Angle Sensor
29a,29b	Non-Return Valve
30a,30b	Rear End Bracket



MAC ♦ N ♦ HOM SYSTEMS
KOCHI - 20

DESIGNATION

Electro-Hydro. Circuit JumboZ-500

DWG. No.

MHS-1835A
(Page 2 of 2)

DATE

02.05.2023